



Tucson Amateur Packet Radio
 8987-309 E. Tanque Verde Rd #337
 Tucson, Arizona 85749-9399
 Office: (940) 383-0000 Fax: (940) 566-2544
 Internet: tapr@tapr.org www.tapr.org
 Non-Profit Research and Development Corporation



T-238 Assembly Manual

This document was written July 2000. © 2000 Tucson Amateur Packet Radio Corp.

Reproduction or translation of any part of this work beyond that permitted by sections 107 or 108 of the 1976 United States Copyright Act (or its legal successor) without the express written permission of Tucson Amateur Packet Radio Corporation is unlawful except as noted below. Requests for permission to copy or for further information should be addressed to Tucson Amateur Packet Radio Corporation. Except as noted above, permission is hereby granted to any non-profit group or individual

to reproduce any portion of this document provided that: the reproduction is not sold for profit, the intent of the reproduction is to further disseminate information on Amateur Packet Radio, the reproduction is not used for advertising or otherwise promoting any specific commercial product, full credit is given to Tucson Amateur Packet Radio Corporation (including address) as the original source of information, and Tucson Amateur Packet Radio Corporation is notified in writing of the reproduction.

The information contained in this document has been carefully checked and is believed to be entirely reliable. However, no responsibility is assumed for inaccuracies. Tucson Amateur Packet Radio Corporation (TAPR) reserves the right to make changes in any products to improve reliability, function or design without obligation to purchasers of previous equipment. TAPR does not assume any liability arising out of the application or use of any product or circuit described herein; neither does it convey license under its patent rights or the rights of others.

INTRODUCTION1
 ACKNOWLEDGMENTS2
 PARTS LIST2
 CONSTRUCTION NOTES3
 CONSTRUCTION.....3
 POWER-UP AND INITIAL TESTING6
 BOARD LAYOUT.....10
 SCHEMATIC DIAGRAM.....11

- WINIDE08 - Integrated Development Environment w/ Assembler
- PROG08SZ - MON08 Flash/EEPROM Programmer
- ICS08Z - In-Circuit Simulator
- ICD08SZ - Real Time In-Circuit Debugger

More information on how to use the T238 debugging functions is available in the T238 Operations Manual at <http://www.beals5.com/wx> or <http://www.tapr.org/taprf/html/Ft238.html>

Introduction

The TAPR T-238 is a general-purpose Motorola MC68HC908GP32 microcontroller-based board intended for use with the Dallas Semiconductor 1-Wire™ bus and any device that needs a serial connection. Four push-button switches and a Liquid Crystal Display (LCD) provide the user interface. The initial application for the T-238 is a controller that accepts data from a Dallas Semiconductor weather sensor unit, processes it, and formats it for sending either directly to a Terminal Node Controller (TNC) for broadcasting in APRS™ format or to a computer for further processing and/or logging. There is nothing about this board that makes it solely a weather station. This is just the first application.

The T238 kit does not come with an enclosure or power supply. It is left up to the builder to find an enclosure that is suitable. For power, the user can use an ordinary wall transformer (“wall wart”) that provides 8-12 Volts DC at 300 milliamps. The T238 is fitted with a 2.1mm power coaxial connector arranged so that the center conductor is positive.

As T-238 programs are developed they will be displayed or linked from the TAPR Weather web site located at <http://www.tapr.org/taprf/html/Ft238.html>. If you’ve created a project and would like to display or link to it, contact TAPR at tapr@tapr.org.

In addition to being a ready-made kit with the weather application pre-programmed into the microcontroller, all the necessary hardware is provided for the more adventurous people to develop their own applications. A list of available development tools for the MC68HC908 can be found at http://mcu.motsp.com/dev_tools/index.html. Free development environment is available from P&E Microsystems at <http://www.pemicro.com/ics08/>. Download the file “ICS08GP Software for 68HC908GP20/GP32” which contains the following programs:

Updated documentation can be found at <http://www.beals5.com/wx> or <http://www.tapr.org/taprf/html/Ft238.html>.

Contributed files can be found at <ftp://ftp.tapr.org/t238/software/>. Files can be anonymously uploaded to <ftp://ftp.tapr.org/t238/upload/>.

T238 is discussed on the Weather Special Interest Group (WXSIG). You can join WXSIG via the web at <http://www.tapr.org/cgi-bin/lyris.pl?join=wxsig>.

Acknowledgments

The Tucson Amateur Packet Radio T238 Kit was made possible by the efforts of (in alphabetical order):

William Beals, N0XGA - Conceptual Designer
Steve Bible, N7HPR - Project Manager
Joe Borovetz, WA5VMS - Parts Liaison
Russ Chadwick, KB0TVJ - Conceptual Designer
Greg Jones, WD5IVD - Asst. Project Manager
John Koster, W9DDD - PCB Design

And Beta Testers:

Rex Blaine, KI0BJ
Steve Dimse, K4HG
Russ Hummel, WB4PGT
Gerald Marchant, WB5NZV
Brian Riley, KA2BQE
Jim Blair, WA5MYI
Joe B. Dorn, W5VEX
Doug McKinney, KC3RL
Aaron Morrison, AE4KO
Guy Story, KC5GOI

PARTS LIST

The parts list is organized by quantity and part type. Verify that all parts are present by checking in the [] as you locate the part in the list. You may wish to take this opportunity to sort the parts into a compartmented container such as an egg carton or muffin tin as you inventory them. This will aid you in kit building.

Resistors 1/4 w, 5% Carbon Film:

[] (1) 10 Ω (brown-black-black) R14
[] (1) 470 Ω (yellow-violet-brown-gold) R12
[] (1) 2.2K Ω (red-red-red-gold) R1
[] (1) 1.5K Ω (brown-green-red-gold) R11
[] (9) 10K Ω (brown-black-orange-gold) R2-R10

Resistor 1/2 w, 5% Carbon Film:

[] (1) 4.7 Ω (yellow-violet-gold) R13

Resistor, Trimpot

[] (1) 10K Ω Trimpot (103) V1

Capacitors

Capacitors may be marked in various ways. The typical markings are listed but may vary. Find all that match and the remaining ones, if any, should become apparent by elimination.

Mylar or Monolithic

[] (5) 0.1 uf (104) C3-C7

Electrolytic or Tantalum

[] (5) 1uF (105 or 1+35) C8-C12
[] (2) 10 uf C1, C2

Diodes

[] (2) 1N4148 Silicon Diode D2, D3
[] (1) 1N5817 Schottky Diode D1

Light Emitting Diode

[] (1) Red T1 DS2

Inductors

[] (8) Ferrite Beads L1-L8

Integrated Circuits

NOTE: Do not handle the ICs at this time! Carefully remove the black foam carrier with ICs from the bag and verify the ICs against this list. Do not touch the ICs! Leave them in the protective foam.

[] (1) MC68HC908GP32CP U3
[] (1) MAX232 or ADM232 U4

Voltage Regulators

[] (1) 7805 TO-220 case U5

Crystal Oscillators

[] (1) 32 MHz U1
[] (1) 9.8304 MHz U2

IC Sockets

[] (1) 16-pin DIP Socket U4
[] (1) 40-pin DIP Socket U3

Switches

[] (5) DPDT Momentary push button switch SW1-SW5

LCD Display

[] (1) 4 line by 20 character LCD module

Connectors

[] (1) 2-pin Molex polarized male header J8
[] (1) 2-pin Molex polarized plug housing
[] (2) Molex crimp pins
[] (2) 1x3-pin male header OJ1, OJ2
[] (1) 2x5-pin male header J9
[] (2) 1x17-pin male header J7
[] (2) 2-pin Jumper, Push-On
[] (2) DE9 Female PCB right angle mount
[] (1) DE9 Male PCB right angle mount
[] (1) 2.1 mm Coaxial Jack J1
[] (1) 2.1 mm Coaxial Plug P1
[] (1) RJ-11 6-6 connector PCB mount J2

Miscellaneous

[] (1) Printed Circuit Board (Rev 2)
[] (1) Assembly Manual (this document)
[] (1) Flat Ribbon Cable Assembly
[] (1) TO-220 heat sink
[] (1) 4-40 x 1/4" screw
[] (6) 4-40 x 3/8" screws
[] (7) 4x40 nuts

Construction Notes

You are now ready to begin construction of the T238. Follow these standard construction practices when building the unit.

Use a temperature-controlled, fine-tipped soldering iron of relatively low wattage (25 watts maximum, 15 watts is ideal) and a good quality 60/40 or 63/37 rosin-core solder for construction. Keep the tip of your soldering iron bright and clean, wiping it frequently on a wet rag or sponge. Make solder joints carefully, but swiftly. Prolonged heat on a PC board pad can be as disastrous as it can ruin the PC board. Two to three seconds should be enough time to apply heat to any joint. Due to the proximity of some of the traces on the PC board, solder bridges are a very distinct possibility. Following the important points above could eliminate several hours of troubleshooting (or worse). This is good practice when working on any kit.

You will need small flush or semi-flush cutting pliers and small-tipped long nosed pliers. A magnifying glass may prove helpful to identify the values of the small components.

Pay careful attention to the directions that follow:

- 1) Read this entire document prior to starting construction of your kit.
- 2) Identifying the pins on headers and ICs - Pin 1 is identified by the square pad on silk-screen.

Electrostatic Protection

The Integrated Circuits and crystal oscillators are susceptible to static discharge. Observe anti-static precautions when assembling the T-238. Never handle the ICs without grounding yourself, the protective foam, and the PCB first. Always touch and hold the foam first before touching the IC. Always touch and hold the printed circuit board before inserting the IC into its socket. Never leave the ICs on anything but the foam or the PCB.

Construction

Refer to the layout diagram for clarification of parts placement. All references to up, down, left, and right assume that you are looking at the PCB with the text right side up, that is the four switches are at the "bottom" and the five big connectors are at the "top".

Resistors

Resistors have a lead spacing of 0.4" and should lie flat on the PC board. You may wish to use a lead former to perform the resistor leads for neatest appearance.

NOTE: – Save the clipped leads as you will use them to solder the ferrite beads in place in a later step.

Install the following resistors:

- [] R1 2.2K Ω (red-red-red-gold)
- [] R2 10K Ω (brown-black-orange-gold)

- [] R3 10K Ω (brown-black-orange-gold)
- [] R4 10K Ω (brown-black-orange-gold)
- [] R5 10K Ω (brown-black-orange-gold)

WARNING! – Be careful when clipping leads, as they have a tendency to fly towards your eyes! Take appropriate precautions (grasp leads and wear eye protection).

- [] Solder and clip the leads (10 total)
- [] R6 10K Ω (brown-black-orange-gold)
- [] R7 10K Ω (brown-black-orange-gold)
- [] R8 10K Ω (brown-black-orange-gold)
- [] R9 10K Ω (brown-black-orange-gold)
- [] R10 10K Ω (brown-black-orange-gold)

[] Solder and clip the leads (10 total)

- [] R11 1.5K Ω (Brown-green-red-gold)
- [] R12 470 Ω (yellow-violet-brown-gold)
- [] R14 10 Ω (brown-black-black)

[] Solder and clip the leads (6 total)

NOTE: R13 is a ½ watt resistor. It is slightly larger than all the other resistors. The lead spacing is 0.5".

- [] R13 4.7 Ω (yellow-violet-black-gold)

[] Solder and clip the leads (2 total)

Field Change Notice 1 – There is an error on the PCB. On the bottom of the PCB there is a trace from R13 to the "+" lead of J8 that crosses over a ground trace.

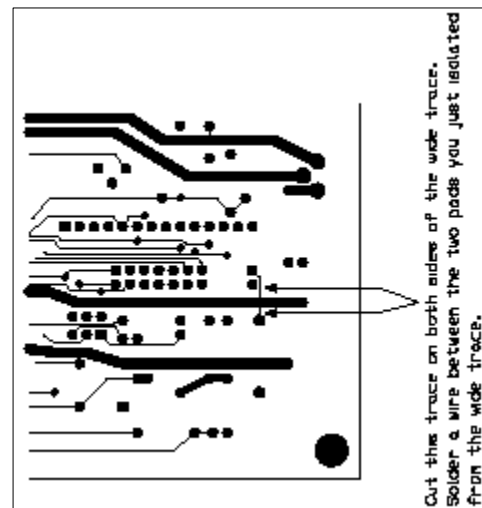

- [] Cut the trace in two places as shown in the figure above pointed to by the arrows.
- [] Solder an insulated jumper wire between R13 and J8 "+" lead.

Now check your work. All leads should be soldered. There should be no solder bridges or cold solder connections.

OK so far.

This completes the resistor installation. You should have no remaining resistors.

No resistors remaining.

Diodes

Diodes are polarity sensitive devices. Diodes are mounted flat near the surface of the board like the resistors previously installed. The cathode end of the diode is banded and corresponds to the banded silk-screen legend on the PCB.

Install the following diodes:

D1 1N5817 Schottky

Solder and clip the leads (2 total)

D2 1N4148

D3 1N4148

Solder and clip the leads (4 total)

Now check your work. All leads should be soldered. There should be no solder bridges or cold solder connections.

OK so far.

This completes the diode installation. You should have no remaining diodes.

One LED remaining.

IC Sockets

NOTE: If any socket pins are bent, carefully straighten them with a pair of long-nose pliers before assembly. Some types of IC sockets have crimps in the pins to hold them in place when automatic wave soldering is performed. These sockets may be tricky to install if you are not familiar with them. If your kit contains these sockets, you may want to straighten the pins before attempting to insert them into the PC board.

When installing IC sockets double check to ensure that the socket is seated properly against the board with the notch matching the silk-screen. Pin 1 (nearest the socket notch) has a square solder pad. Be sure that all IC socket pins are showing on the solder side of the board. Next, tack-solder two diagonally opposite corners first (such as pins 1 and 8 on a 14-pin socket).

Then solder the remaining pins of that socket before proceeding to the next one. If you find a socket is difficult to install, remove it and double-check for a bent pin.

CAUTION! – Take care to avoid solder bridges!

Install the following IC sockets. Align the notch in the socket to the notch in the silkscreen outline:

U3 40-pin

U4 16-pin

Now check your work. All leads should be soldered. There should be no solder bridges (a blob of solder that shorts two adjacent soldered connections) or cold (gray and/or grainy looking) solder connections.

OK so far.

This completes the IC socket installation.

Capacitors

All capacitors should be mounted as nearly flush to the board surface as practical without stressing the leads.

Install the following capacitors:

C3 0.1 uF (104)

C4 0.1 uF (104)

C5 0.1 uF (104)

C6 0.1 uF (104)

C7 0.1 uF (104)

Solder and clip the leads (10 total)

Electrolytic and Tantalum capacitors are polarized. The positive lead goes in the hole on the board marked with a "+". Be careful! Typically the negative lead is marked but sometimes the positive lead is marked.

NOTE: The orientation of the of the positive "+" leads are not all the same.

C8 1 uF (105 or 1+35)

C9 1 uF (105 or 1+35)

C10 1 uF (105 or 1+35)

C11 1 uF (105 or 1+35)

C12 1 uF (105 or 1+35)

Solder and clip the leads (10 total)

C1 10 uF

C2 10 uF

Solder and clip the leads (4 total)

Now check your work. All leads should be soldered. There should be no solder bridges or cold solder connections.

OK so far.

This completes the capacitor installation. You should have no remaining capacitors.

No capacitors remaining.

Ferrite Beads

Ferrite beads are cylinder shaped. String a clipped lead from a resistor or capacitor through the ferrite bead. Position the ferrite bead over the silkscreen outline and insert the leads into the solder holes. Solder the leads and clip them flush on the bottom of the PCB.

Install the following ferrite beads:

- L1
- L2
- L3
- L4
- L5
- L6
- L7
- L8 (Install the ferrite in the solid silkscreen outline. This is the normal position. The dashed outline is an alternate position.)

- Solder and clip the leads (16 total)

Trimpot

Align the trimpot according to the silkscreen.

Install the trimpot:

- V1 10K ohm

- Solder and clip the leads (3 total)

Light Emitting Diode (LED)

LEDs are polarized components. The flat side on the base and the shorter lead identifies the cathode lead. Insert the LED according to the silk-screen outline, the flat side or short lead to the flat side of the silkscreen

- DS2 Red LED

- Solder and clip the leads (2 total)

Male Headers

The male headers will be installed next. The plastic body of the part should rest flush with the top surface of the PC board. Note that the short end of the pins go into the PC board, the long end sticks up.

WARNING! – Do not hold these parts with your fingers while soldering. The pins get very hot.

Place a 2-pin jumper on the header to insulate your finger from the pins, hold the header in place and tack solder one pin. Check for proper alignment. If alignment is off, you can reheat the one pin to adjust. Once the alignment is correct, solder the rest of the pins and then reflow (reheat) the first pin you soldered.

- OJ1 1x3 male header
- OJ2 1x3 male header
- J6 2x8 male header
- J9 2x5 male header

Header J10 is a 1x14-pin male header. A 1x17-pin male header is supplied in the kit. Carefully trim 3 pins off one end of the header to make a 1x14-pin header.

- Trim 1x17-pin male header to 1x14-pins.
- Solder the 1x14-pin male header to J10.

Header J8 is a polarized 2-pin male header. Align J8 to the silkscreen on the PCB and then solder.

- J8 1x2 male header, polarized

Jumpers

Install the 2-pin push-on jumpers in the following locations:

- OJ1 short pins 1 and 2 (center to left)
- OJ2 short pins 1 and 2 (center to left)

Crystal Oscillators

Install the following crystal oscillators. The orientation of these devices is important. Pin 1 is marked on the PCB with a square pad. Pin 1 on the crystal oscillator is marked with a black dot and/or an edge of the can that is square instead of rounded.

- U1 32.000 MHz
- U2 9.8304 MHz

- Solder and clip the leads (8 total)

Connectors

Gently rock the RJ-11 connector until it snaps into place and solder the leads.

- J2 RJ-11 connector

CAUTION! – Soldering the coaxial power connector is a bit tricky because of the large mounting holes.

- J1 Coaxial power connector

Install the DE-9 connectors in their respective locations. Secure the connectors using two 4-40 x 3/8" screws and 4-40 nuts per connector before soldering the pins.

- J3 DE-9 female
- J4 DE-9 female
- J5 DE-9 male

- Solder the leads

Switches

Install five miniature DPDT momentary switches. Position them according to the silkscreen and solder the leads and body mounting pins. The polarity of the switches is important. Note that on the silkscreen the left side of the switch outline shows two dimples while the right side only shows one. Look down on the top of the switch and you will notice that one side the black plastic shows through the

white plastic twice on one side and once on the other. Insert the switch such that the side with two pieces of black plastic protruding matches the silkscreen outline with two dimples.

- SW1
- SW2
- SW3
- SW4
- SW5

- Solder the leads

Voltage Regulator Heatsink

Align the heatsink on the regulator and attached it using the 4-40 x 1/4" screw and one nuts to secure the two.

- Mount and bolt the heatsink to the regulator.

Voltage Regulator

NOTE – Voltage regulators are polarized components. Match the body of the voltage regulator with the silk-screened outline. The metal tab should be toward the outside of the board. Carefully bend the leads to match the hole pattern on the PC board. The bottom of the body of the voltage regulator should not be more that 1/4" above the PC board.

- U2 7805

- Solder and clip the leads (3 total)

LCD Module

Now you will prepare the LCD module for connection to the T-238 PCB. The LCD connects to the PCB via a flat ribbon cable and two wires (red and black) that power the LED backlight.

- Carefully remove the LCD module from its protective packaging.

You will be soldering a 1x14-pin male header to the LCD. During this time you need to protect the LCD screen from splatter while soldering.

- Cover the LCD screen while soldering.

- A 1x17-pin male header is supplied in the kit. Carefully trim 3 pins off one end of the header to make a 1x14-pin header.

- Position the 1x14-pin male header to the rear of the LCD in the holes on the top of the display. These are the holes labeled with a 1 on one end and a 16 on the other. Put the header in holes 1 through 14. There will be two holes (15 and 16) left open.

- Solder the 1x14-pin male header with pins facing to the rear of the LCD module and in holes 1 through 14.

- Locate the red and black wires in the kit. Strip 1/8-inch of insulation off each end of both wires. Tin the ends with solder.

- Locate the two crimp pins in the kits. Crimp one pin to the red wire and one to the black wire. You may carefully heat the pins so that the solder on the wire adheres to the crimp pin. Take care not to foul the crimp pin with solder.

Locate the 2-pin polarized connector housing. Position it over J8. Note the pinhole that is nearest the silkscreen "+" on the PCB.

- Carefully insert the red wire crimp pin end into the housing corresponding to the hole nearest the "+" on the PCB. The pin should slip smoothly into the housing and click into place.

- Carefully insert the black wire crimp pin into the housing in the second hole.

WARNING! – It is very important that the red lead connect to the "+" on the PCB. Improper connection will result in reverse polarity of the LED backlight on the LCD display.

- Double check that when the connector is plugged into J8 that the red lead is nearest the silkscreen "+" on the PCB.

- On the rear edge of the LCD display, locate the solder pads labeled "LEDA" and "LEDC" (these correspond to the LED backlight anode and cathode).

WARNING! – You do not want to solder to the two inner bare solder pads next to the LEDA and LEDC pads. Solder the red and black wire to the pads with solder on them directly next to the silkscreen labels LEDA and LEDC.

- Solder the red wire to "LEDA."

- Solder the black wire to "LEDC."

That completes the assembly of the LCD module cables. Set them aside for now. The LCD module will be connected to the PCB after a few voltage checks are completed in the next section.

Almost done

At this point, these should be the only items left

NOTE: Keep U3 and U4 in the antistatic foam

- U3 MC68HC908GP32
- U4 MAX23

- 2.1 mm Coaxial Plug

You are almost finished assembling the PCB. Next you will do some final checks before applying power.

Power Up And Initial Testing:

In this section you will slowly power-up the board and check for assembly errors. It is important that you follow these steps carefully. You will systematically apply power to sections of the board while checking voltages to find and eliminate errors. Errors take two forms, the kind that damage components and the kind that don't. Neither is desirable, but the kinds that damage components will require you to find a replacement part.

Before applying power for the first time, please check the following:

ICs U3 and U4 are NOT installed.

Check that oscillators U1 and U2 are oriented correctly. Three of the corners are rounded and one is squared. The squared corner is pin 1 and should match the square pad on the printed circuit board.

Check the polarity of all the electrolytic or tantalum capacitors. The capacitors negative side is usually identified with a white stripe and a big minus sign on it. The positive side is identified on the PCB. Not all the capacitors have the same orientation; double-check them with reference to PCB silkscreen.

Check the polarity of diodes D1, D2, and D3. The band on the diode should match the extra stripe on the PCB silkscreen.

Headers J6, J7, J8 and J10 are not connected.

The LCD should not be plugged in.

Jumpers OJ1 and OJ2 have jumper between pins 1 and 2.

The T238 kit does not come with a power supply. An ordinary wall transformer ("wall wart") that provides 9 to 12 Volts DC at 300 milliamps will work fine. The T238 is fitted with a 2.1mm power coaxial connector such that the center conductor is positive and the outer barrel is ground. Measure this with a voltmeter to confirm both the voltage, but more importantly, the polarity. The Radio Shack Model 19-1120/19-1140, supplied with the HTX-202 and the HTX-404 handheld radios, is suitable for this application.

The voltage is between 9 and 12 Volts DC

The center conductor is positive and the barrel is ground

Apply power to the T238. Observe anything unusual such as components heating up, smoke or smell. Remove power immediately if anything unusual appears.

Place the ground lead of your voltmeter on pin 2 of U3. This will be the ground reference for the rest of the measurements.

Measure the voltage on the voltage regulator U5 on the pin furthest from the power jack. It should be between 8 and 14V. If it is 0V, then L1 is likely missing or damaged. If it is low, the transformer may not be rated for the right voltage or something may be overloading it.

Measure the voltage on the voltage regulator U5 on the pin closest to the power jack. It should be between 4.90V and 5.10V. If it is low, something could be overloading the regulator and whatever is doing that should be hot.

WARNING! – Don't proceed until the voltages in and out of the voltage regulator U5 are within proper limits.

Voltages in and out of voltage regulator U5 are within limits.

NOTE – In the sections below, there are frequent references to +5V, which actually means the voltage between 4.90V and 5.10V that you measured above.

With the ground lead of your voltmeter still on U3 pin 2, confirm all the following test points also measure +5V. Remedies are listed if you do not see +5V.

Check	Pin	Remedy if not +5V
<input type="checkbox"/>	U4 pin 16	Check socket.
<input type="checkbox"/>	J2 pin 2	Check socket and L8
<input type="checkbox"/>	J2 pin 3	Check socket, L2, and R11
<input type="checkbox"/>	U3 pins 1, 20, and 31	SW5 possibly installed backwards. Check by pressing SW5. If voltage appears when the switch is pressed, it is in backwards.
<input type="checkbox"/>	U3 pin 14	Check OJ2

Next check the four switches following the table below. For each pin on the microcontroller, verify that the voltage is normally 5V. Pressing the switch makes the voltage go to 0V. If the voltage is always low (regardless of the switch), then likely the resistor is not installed correctly. If the operation is opposite (normally low and pressing the button makes the voltage go high), then the switch has been installed backwards.

Check	U3 Pin number	Switch	Resistor
<input type="checkbox"/>	U3-26	SW4	R10
<input type="checkbox"/>	U3-27	SW3	R9
<input type="checkbox"/>	U3-28	SW2	R8
<input type="checkbox"/>	U3-29	SW1	R7

Using a small wire bent in a U-shape, short between U3 pins 20 and 21. Do this carefully so you don't damage the IC socket. The LED should light. If it does not, there is a problem with R12 or more likely, the LED is installed backwards.

LED works

Remove power from the T238.

Next you will insert U3 and U4. Make sure you match the pin-1 notch of the device to the notch on the silkscreen. There are a lot of pins on U3 and it can be difficult to line them up with the socket. Your best bet is to place the chip sideways on a flat static-safe surface so that one row of the pins all lie flat on the surface. Carefully rotate the body of the IC while pushing down on the pins. Rotating while pushing down should bend all the pins together and bend them where they protrude from the body. Bend the pins a little at a time, then check to see if they are perpendicular to the body of the IC. Once perpendicular, the pins of the IC will be much easier to insert as they line up with the socket.

Insert U3 slowly. Observe that all the pins slide into the socket. Watch for pins that bend under the IC or out of the IC socket. Follow the same process for U4.

[] Insert U3, MC68HC908GP32

[] Insert U4, MAX232

[] The notch on the chip is aligned with the silkscreen notch on the PCB.

[] Apply power to the T238. LED DS2 will flash three times quickly, and after approximately 10 seconds it should start flashing once per second.

If LED flashes after approximately 30 seconds and flashes once every three seconds, then either OJ1 in the wrong position (jumper between pins 1 and 2) or you have the crystal oscillators swapped. If the jumper is in the wrong position, power down the T238 prior to changing jumpers.

If the LED does not flash at all, check OJ2 (jumper between pins 1 and 2). If the jumper is in the wrong position, power down the T238 prior to changing jumpers.

If the LED still does not start flashing, make sure that all the pins in U4 were inserted cleanly into the socket and check the following components carefully: R1, R2, R3, R4, R5, and R6. Do not proceed until the LED flashes as described above.

[] LED flashing approximately once per second

With a the ground lead of your voltmeter on pin 15 of U4, check the following voltages:

Check	Pin	Voltage	Remedy
[]	U4 Pin 16	+5	Check IC socket
[]	U4 Pin 2	Greater than 8V	Check IC socket, C8, C9, C10, C11
[]	U4 Pin 6	Less than -8V	Check IC socket, C8, C9, C10, C11

[] Remove power from the T238.

[] Locate the flat ribbon cable. Notice that one of the leads nearest one of the edges is a bluish color compared to the rest. This lead denotes pin 1. You may wish to place another indication of pin 1 such as a sticker on the connectors.

NOTE: – The flat ribbon cable will have to twist in order to plug it into pin 1 on the PCB.

WARNING! – Polarity of the flat ribbon cable must be observed. Pin 1 of the LCD display must match pin 1 on the PCB.

[] Plug the LCD cable into J10; line up the bluish stripe of the cable with pin 1 on the silkscreen. Pin 1 on the PCB is identified with the square pad and square around it. It is closest to U3.

[] Plug the other end of the flat ribbon cable into the LCD. Line up the cable bluish stripe with pin 1 of the LCD module.

[] Plug the LCD display LED backlight polarized connector into J8. Verify that the red lead plugs into the pin next to the “+” symbol on the PCB.

[] Cable installed with marked wire next to Pin 1 on T238 and display.

Place multi-meter in Ohms mode.

Measure the resistance between U3 pin 2 and pin 1 on the LCD module. The resistance should be less than 1 ohm. If not, the cable is either bad or installed backwards.

[] Resistance from U3-pin 2 to LCD pin 1 is less than 1 ohm.

[] Measure the resistance between U3 pin 1 and pin 2 on the LCD module. The resistance should be less than 1 ohm. If not, the cable is either bad or installed backwards.

[] Resistance from U3-pin 1 to LCD pin 2 is less than 1 ohm.

[] Insert the two-wire cable from the LCD in to the J8 Molex connector. Make certain the red wire is toward the + marking in the silkscreen.

[] Adjust VR1 to mid-position.

[] Apply power to the T238.

[] After about 1 second you should see the opening banners displayed on the LCD module. If you do not see them or they look dim or overly dark, adjust VR1, the LCD contrast adjustment. Fine tune VR1 for best viewing. If text is not visible, check the soldering on U3 and J7 as well as the LCD cable and the header on the LCD module.

[] LCD showing legible text.

During the power up sequence, you will get a message saying that there is a 1-wire bus error. If the error says no devices are present, you are OK. If it says the bus is shorted to ground, then check U3, J6, D2, D3, R11, L2, and J2 for assembly problems or bad solder joints.

Do not select any menu options at this time.

Received error message saying no devices on the bus.

If you haven't already done so, assemble the Dallas Semiconductor 1-Wire™ sensor unit using the instructions on the web site <http://www.ibutton.com/weather/assembly.html> and confirm that it works with the supplied PC software.

Weather station sensor unit works with PC software

Remove power from the T238.

Plug in the supplied telephone cable into J2 and in the weather sensor unit. A good approach here is to mount the 1-Wire weather station sensor unit to a bench with a C-clamp, aligning the aluminum square tube in the same orientation that it will have when the weather sensor unit is permanently mounted outside.

Apply power to the T238. The LCD should display its opening messages. If the LCD says that the 1-Wire bus is

shorted then most likely the 1-Wire bus has been reversed. This will not cause any damage, but the unit will not work. Some telephone cables reverse the wires and some do not. In addition, some telephone cord couplers reverse the wires. Find a telephone cable that does not reverse the wiring.

Hold the connectors side-by-side and oriented the same direction (for example, the clip tab down on both connectors). Observing the red and green wires inside. If, for example, red is on the left in both connectors, then this cable does not reverse the signal wires.

When the weather sensor is connected properly, the LCD will not give any bus error messages. It will complain that it has no IDs and will ask that your run setup. This is perfectly normal.

No bus error messages at all when powering up the weather station.

Congratulations!

You have completed the power-up and initial testing phase! To learn how to setup and operate your T238 APRS™ 1-Wire™ Weather Station, please refer to the T238 Operations Manual. It is available on the T-238 web site at <http://www.beals5.com/wx> or <http://www.taprf.org/taprf/html/Ft238.html>

Drill tape data			
Tool Code	Hole Size	Sym bol	Hole Count

Board type: FR4
 Board thickness: .062"
 Copper weight: 2oz

All dimensions are in inches.

Board should have green solder mask over bare copper (SMDPC) with white silk screening on top.

View is from the top side of the board.

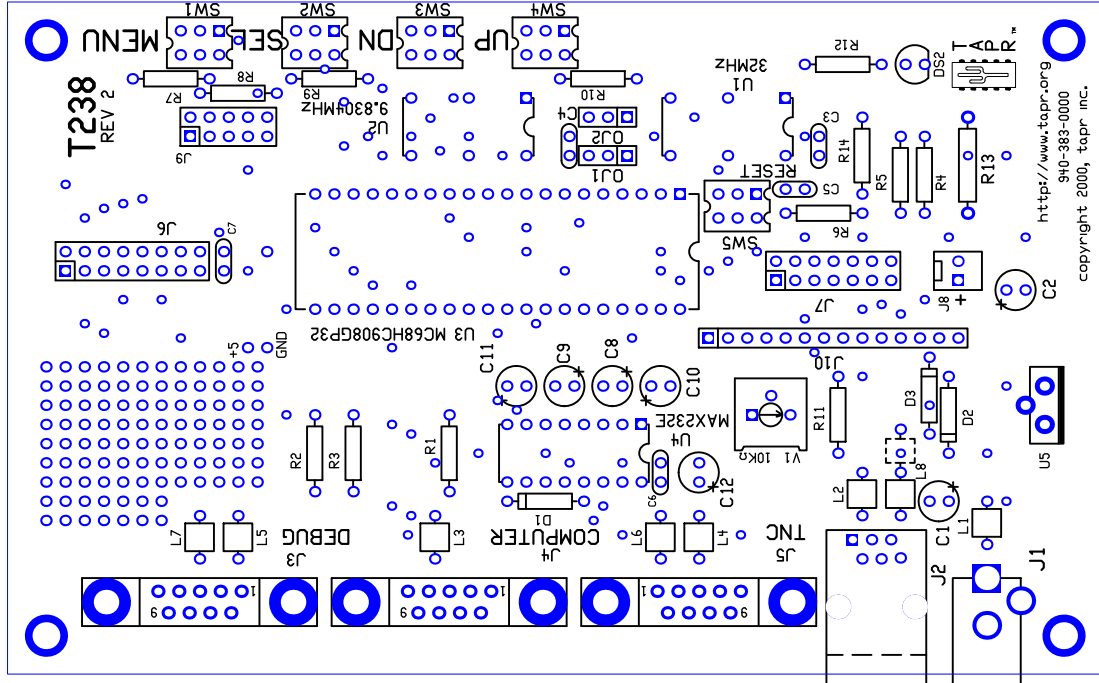

Co:	TAPR, Inc.
Title:	1-WIRE WX Station
Board:	WXSTN
Drawn:	J. Koster, W9DDD
Date:	9-20-99
Revision:	2
Size:	A
Sheet	1 of 1

<http://www.tapr.org>
 940-383-0000
 copyright 2000, tapr inc.

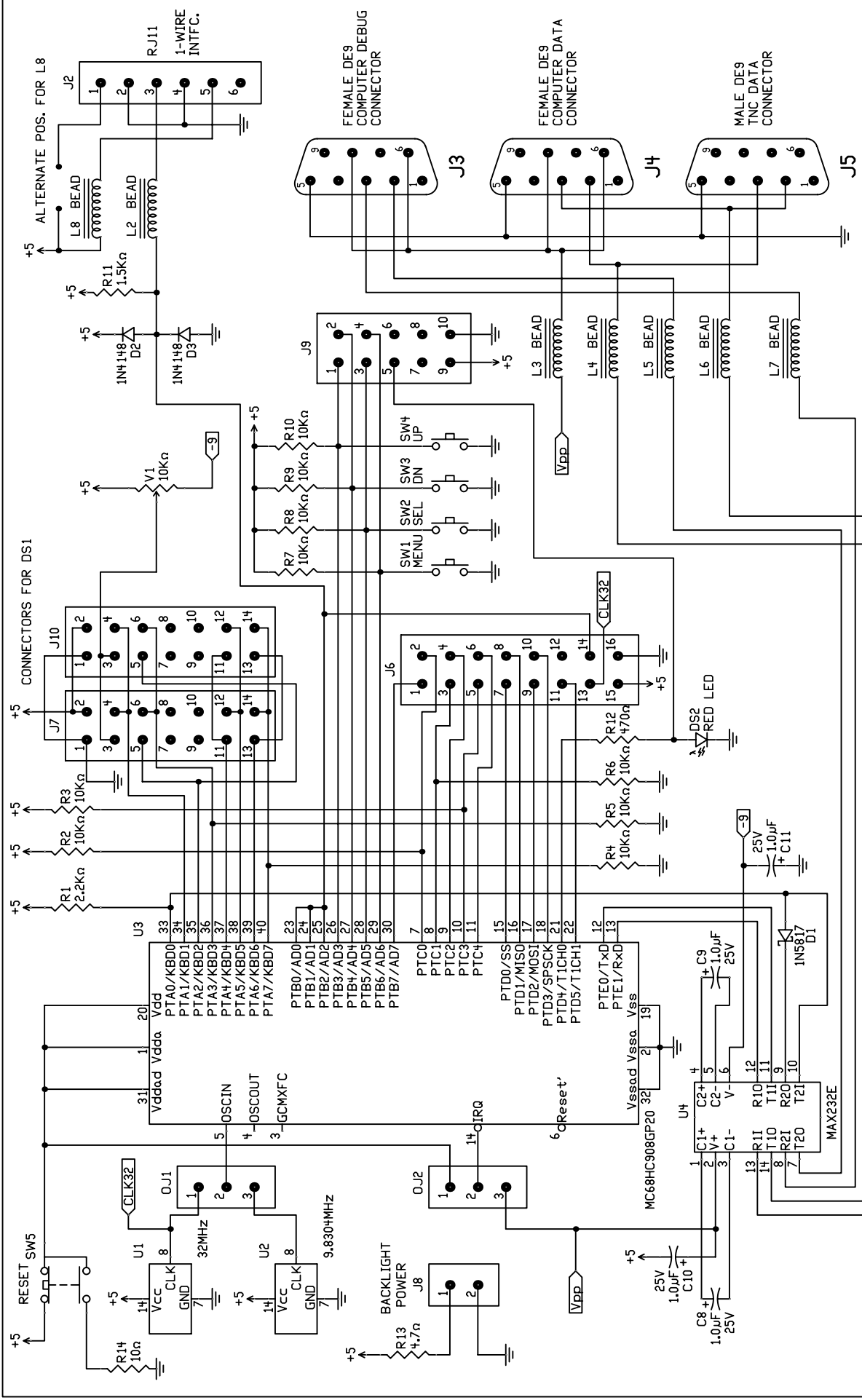

Co:	TAPR, INC.		
Title:	1-WIRE WX STATION		
Board:	WXSTN - BOARD	Revision:	B
Author:	Will Beals N0XGA	Size:	A
Date:	5/2/00	Sheet 1 of 2	

